

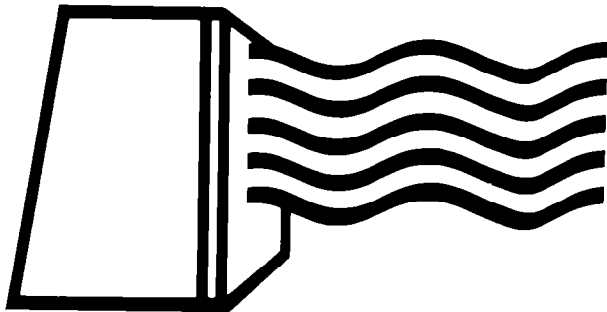

AIR CONDITIONER

USE & CARE GUIDE



IMPORTANT...

Please read this use and care guide before installing or using your air conditioner. It tells you how to install and operate it, and gives important electrical information. Save it for future use in case you may have a question or move the air conditioner.

Table of Contents	Page
Before You Use Your Air Conditioner	2
Energy Tips	2
Cooling Load Guide	2
How to Start and Use Your Air Conditioner ...	3
Cleaning and Care	4
Electrical Requirements	6
Installation Instructions	9
Self-Service Check List	16
Service Information	16

CAUTION:
Handle the air conditioner with care. Watch out for the sharp metal fins on the front and rear coils.

NOW...

Is a good time to fill in the spaces below. You will need this information if you call for service or ask questions about your air conditioner. Model and serial numbers are on a plate attached to the front of the unit. You can see it after removing the plastic front panel.

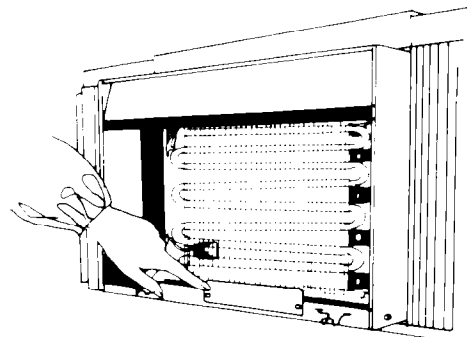

Model No. _____

Serial No. _____

Purchase Date _____

Service Co. Phone No. _____

BEFORE YOU USE YOUR AIR CONDITIONER

**It is your responsibility
to make sure that your new
air conditioner:**

- Has been properly installed.
- Is the right size for the area you want to cool.
- Is properly connected to electricity.
- Is properly electrically grounded.
- Is properly used only for the job it was intended to do.
- Is not used by children or anyone not able to operate it properly.
- Is properly maintained.
- Also, remove energy label and buy guide. Use damp cloth to take off any glue residue. Do not use a sharp instrument or any harsh or abrasive cleaners.

Energy Saving Tips

- Improve home insulation (seal doors, windows, and close fireplace flue).
- Close blinds or drapes on sunny side of house; add window awnings.
- Keep air filter clean. Don't block air flow with drapes or furniture.
- Ventilate attic (high temperature levels add to normal cooling load).
- Try not to use heat producing appliances during the hottest part of the day. Turn lights, radios, televisions, and other appliances off when not needed.
- Keep heat registers and cold air returns closed or blocked off so cooled air won't escape.
- Use a vent fan in areas where cooking, laundry, or bathing is done to pull out extra heat and moisture near its source.
- Use the energy saving settings.

COOLING LOAD GUIDE — SQUARE FEET METHOD ROOM AIR CONDITIONERS

To make sure you choose the right size unit, use this "COOLING LOAD GUIDE — SQUARE FEET METHOD." It is a quick, easy means of computing capacity.

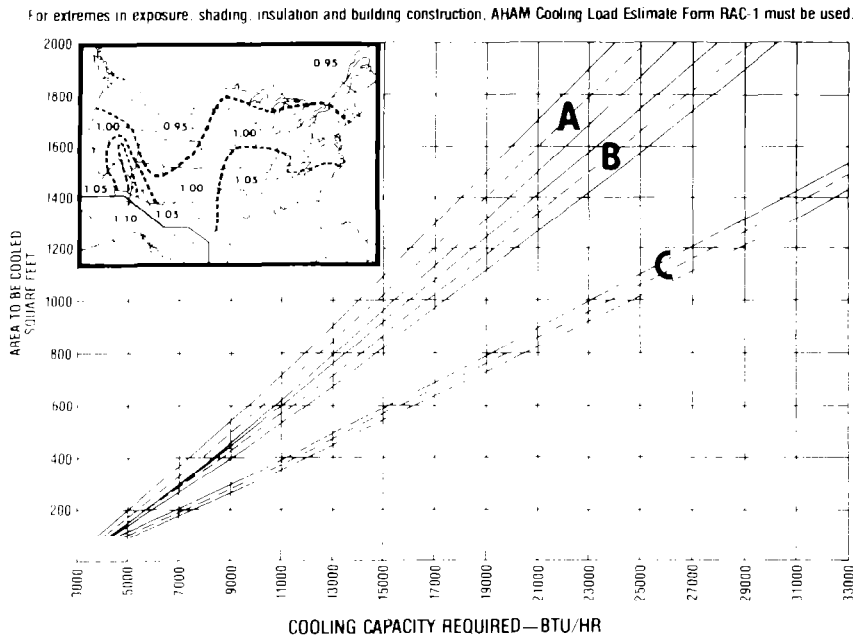

INSTRUCTIONS:

1. Determine the area to be cooled in square feet and locate that point on the left side of chart.
2. Move horizontally across to the center line of Band A, B or C according to the condition of the ceiling in the area to be cooled.
Band A—Occupied Space Above Ceiling
Band B—Insulated Ceiling Under Attic
Band C—Non-Insulated Ceiling Under Attic
3. From center of band move within the band to left for more northerly exposure or right for more westerly exposure.
4. From this point, read down to bottom of chart to determine required Btu/hr output. Write the Btu/hr figure in the space indicated below.

5. _____ Btu/hr (from number 4 above)

6. Locate your geographic area on inset map and multiply factor shown by figure in number 5.
7. If room air conditioner is intended primarily for night-time cooling, subtract 30% (from figure in number 6).
8. Subtract 30 Btu/hr from figure in number 7 (or 6) for each linear foot of wall separating the area to be cooled from another cooled room.
9. If more than two people occupy area, add 600 Btu/hr per person (to figure in number 8); if only one person, subtract 600 Btu/hr.
10. Add 4000 Btu/hr (to figure in number 9) if area to be cooled includes kitchen.

For best results, a room conditioning unit or units with a cooling capacity rating close to that estimated above should be selected. A smaller capacity unit operating continuously will contribute more to comfort than a larger capacity unit operating intermittently.

How to Start and Use Your Air Conditioner

Be sure air conditioner is OFF before plugging it in.

Choose the control panel drawing that matches the control panel of your air conditioner.

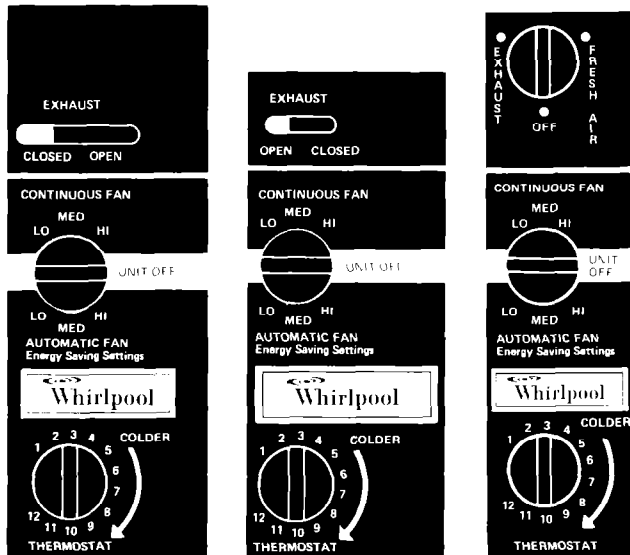

1. To start your air conditioner:

- Choose either CONTINUOUS FAN or AUTOMATIC FAN.

CONTINUOUS FAN — Fan runs all the time, even as thermostat turns compressor on and off.

AUTOMATIC FAN (ENERGY SAVING SETTINGS) — The fan cycles on and off with the compressor, saving the cost of electrical energy used to run the fan continuously.

When the energy saving setting is selected, no air is circulated during these off periods. This setting can be used during periods when rooms are not being used continuously, when weather is not extremely hot or humid, and for areas that do not need to be extremely cool (infant or elderly person's room, etc.).

- If there are times when the "energy saving setting" temperature variation is not satisfactory, or during extremely warm, humid weather, and for areas of high activity which need to be constantly cool, use **CONTINUOUS FAN** settings.

When the unit is set on **AUTOMATIC FAN**, it is normal for it to turn on and off. The length of time the unit will be off depends on room temperature and thermostat setting.

- Choose either LO, MED, or HI FAN SPEED on continuous or automatic fan settings.

LO — for sleeping comfort
MED — for normal cooling
HI — for maximum cooling

CAUTION:

If you turn your air conditioner off, wait at least two minutes before turning it back on or you may blow a fuse.

2. Set THERMOSTAT by turning knob towards higher numbers for maximum cooling. Lower number settings result in warmer room temperature. You will need to experiment to find the setting which suits you best.

3. EXHAUSTING ROOM AIR. Use your air conditioner to exhaust stale, smoky air — with or without cooling.

For EXHAUST controls with settings OPEN and CLOSED:

- Set EXHAUST on OPEN.
- Adjust fan control to continuous fan settings and to speed desired.
- Set thermostat on #1 if no cooling is desired. Turn thermostat to a higher number if you want cooling also. For maximum cooling, set EXHAUST on CLOSED.

— or —

For EXHAUST controls with settings EXHAUST and FRESH AIR:

- **To exhaust room air**, set on EXHAUST. Adjust fan control to continuous fan and speed desired. Set thermostat on #1, if no cooling is desired.
- **To bring in outside air**, set on FRESH AIR. Adjust fan control to continuous fan and speed desired. Set thermostat on #1, if no cooling is desired.
- **To circulate room air**, set EXHAUST/FRESH AIR control on OFF. Set thermostat to #1. Adjust fan control to continuous fan and desired speed setting.
- **For maximum cooling**, set EXHAUST/FRESH AIR control on OFF.

Changing Air Direction

The louvers in the grille area at the top of the air conditioner control the direction of the cooled air.

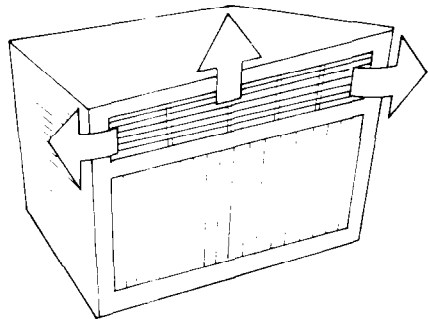

1. Move the levers at the top or bottom of the grille to the right, left or straight ahead. Simply move the levers in the direction you want the air to go.
2. On most models, the louvers can only be adjusted left or right. The front set is fixed and directed upward.
3. On some models, air flow can be directed up or down. Move the tab in the center louver to direct air.
4. On some models, all louvers are fixed. The louvers can not be adjusted.

Cleaning and Caring for Your Air Conditioner

Proper use and care of your air conditioner will help insure longer life and lower operating costs. Follow these instructions carefully. Call your dealer for an annual checkup.

The filter is cleanable. A clean filter helps remove dust, lint, and other particles from the air. Check every two weeks to see if filter needs cleaning.

CAUTION:

Do not use cleaning fluids, solvents, abrasive cleaners, or strong detergents. They may damage the parts.

Cleaning of Front Frame

WARNING: DISCONNECT FROM ELECTRICAL SUPPLY BEFORE CLEANING UNIT.

1. Remove the front frame from unit when cleaning (as shown below).
2. Clean front frame with warm water and mild soap or detergent. Use a soft cloth. Rinse and dry. Replace front frame.
3. Wipe control panel clean with a soft dry cloth.

Cleaning the Filter

Check every two weeks to see if filter needs cleaning.

1. To remove front frame, press down at top edge of front.

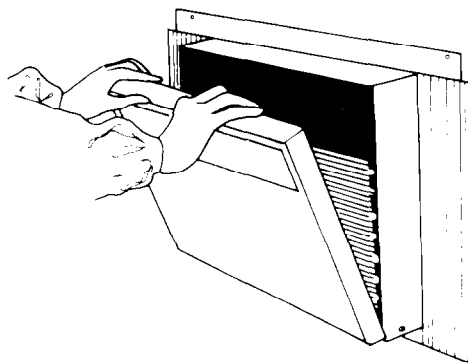

2. When front moves away from top of cabinet, pull top of front toward you.
3. Lift up and away from bottom spring clips.

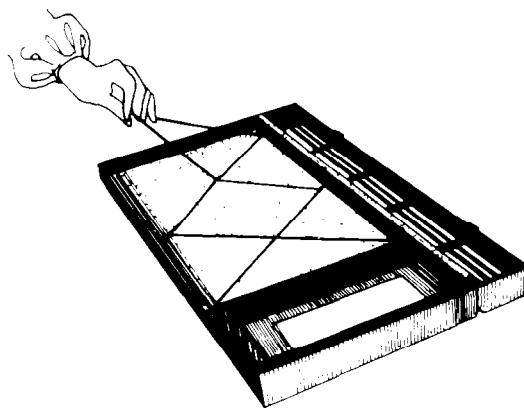

4. Remove filter from plastic front frame, by removing elastic band which holds it in place.
5. Clean filter, using a vacuum cleaner.

— or —

6. If very dirty, wash filter with warm water and mild detergent. Air dry thoroughly before replacing.

Annual Maintenance for Your Air Conditioner

Your air conditioner needs annual maintenance to help insure steady, top performance throughout the year.

Call the service company recommended by your dealer to:

- Inspect and clean the coils and condensate water passages
- Check fan and oil the fan motor.
- The compressor is sealed and needs no oiling.

— or —

If you are familiar with electrical appliances, you can do the cleaning and maintenance yourself. If you decide to go ahead, follow these steps:

CAUTION:

Be sure no liquid gets into the motor, electrical control box or compressor electrical terminals.

- 1. DANGER—SHOCK OR INJURY HAZARD** — before performing any maintenance be sure to disconnect power cord from receptacle.
- 2. REMOVE UNIT FROM CABINET.** Wrap the motor, electrical control box and electrical terminals box in aluminum foil or plastic, and make sure no water or other liquid gets inside any of these parts. It could damage the insulation and cause serious trouble.
- 3.** Carefully clean and hose out the base, coils and condensate pans. Clean at least once a year or more often, if the condenser coils and pans collect dirt, sand, leaves, insects or algae. Also, clean if you detect an odor from the air conditioner. While the cabinet is open, this is a good time to oil the fan motor.
- 4.** Remove foil or plastic from motor and electrical parts.
- 5.** Replace unit in cabinet.

NOTE: It's a good idea to wait 24 hours before starting the unit again. This allows time for all areas to dry out. The water from rainfall or from normal operation does not harm these components.

Oiling of the Fan Motor

- 1. DANGER—SHOCK OR INJURY HAZARD** — before performing any maintenance be sure to disconnect power cord from receptacle.
- 2.** Oil the fan motor per instructions on the motor. To add oil, pull out the oil hole plug at each end of the motor.

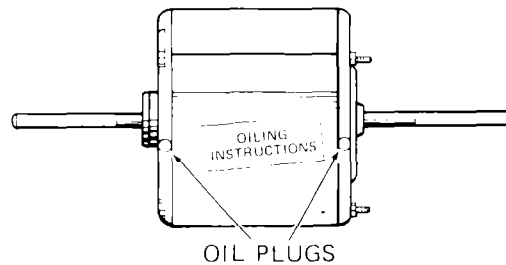

An easy to use one-ounce capsule of especially recommended oil (Part No. 10943) can be ordered from your dealer.

- 3.** Replace the plug to keep dirt from motor bearings.
- 4.** Reinstall unit in cabinet after performing maintenance.

Electrical Requirements For Your Air Conditioner

IMPORTANT: Read model and serial plate behind the front panel (to remove front panel, see page 4) to determine which electrical requirement instructions to follow. For plug type shown in Figure 1, ... if ampere (amps) is 6.0 through 7.5 follow A — ELECTRICAL REQUIREMENTS. Ampere 7.6 through 12.0 follow B — ELECTRICAL REQUIREMENTS, page 7. If the plug type matches the one shown in Figure 2, follow C — ELECTRICAL REQUIREMENTS, page 8.

Figure 1

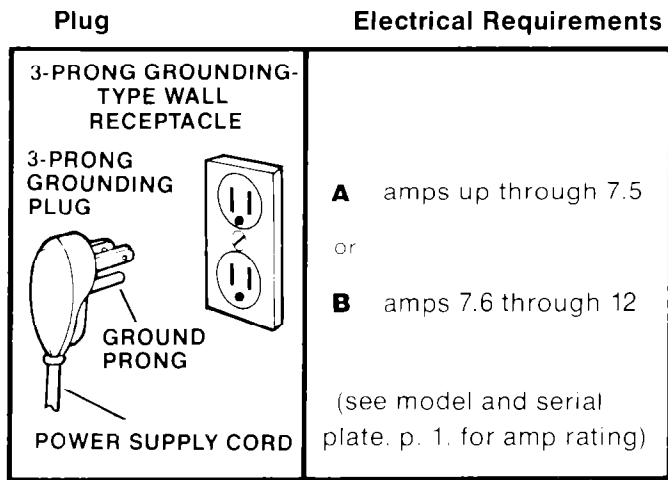
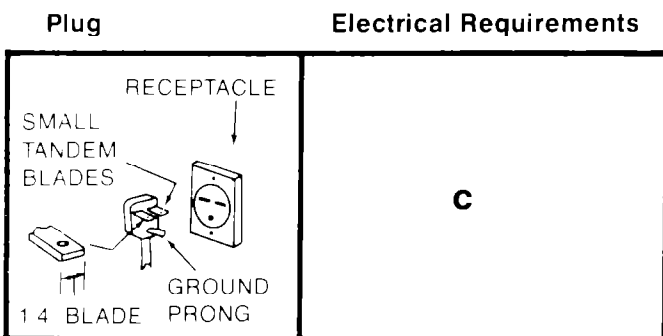
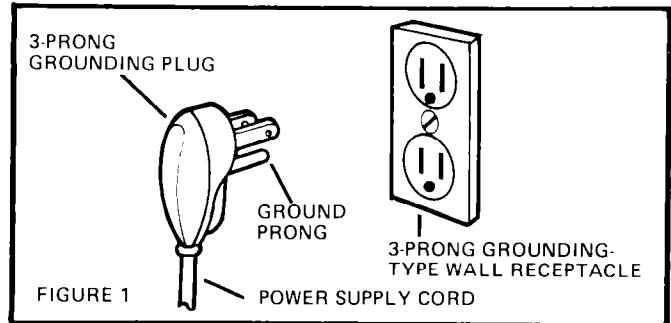

Figure 2



RECEPTACLE WIRING

RECEPTACLE WIRING should be at least as large as 14 gauge. Use copper wire only. It is the personal responsibility and obligation of the customer to provide proper and adequate receptacle wiring installed by a qualified electrician. OBSERVE NATIONAL ELECTRICAL CODE AND ALL LOCAL GOVERNING CODES AND ORDINANCES.



Electrical Connection

Electrical Ground Is Required on This Appliance

Recommended Grounding Method

For your personal safety, this appliance must be grounded. This appliance is equipped with a power supply cord having a 3-prong grounding plug. To minimize possible shock hazard, the cord must be plugged into a mating 3-prong grounding type wall receptacle, grounded in accordance with the National Electrical Code and local codes and ordinances. If a mating wall receptacle is not available, it is the personal responsibility and obligation of the customer to have a properly grounded 3-prong wall receptacle installed by a qualified electrician. See Figure 1.

Alternate Grounding Method

If changing and properly grounding the wall receptacle is impossible and where local codes permit (consult your electrical inspector), a temporary adapter may be plugged into the existing 2-prong wall receptacle to mate with the 3-prong power supply cord. See Figure 2. THIS, HOWEVER, IS NOT RECOMMENDED.

If this is done, you must connect the grounding eyelet on the adapter to the wall receptacle cover plate screw and from this same screw, you must connect a separate copper ground wire (#14 minimum) to a grounded cold water pipe.* **See Figure 2 on Page 7.** Do not ground to a gas supply pipe. Do not connect to electrical supply until appliance is permanently grounded.

A ELECTRICAL REQUIREMENTS

for 115 volt models with nameplate amps up through 7.5

OBSERVE ALL LOCAL GOVERNING CODES AND ORDINANCES

Do not, under any circumstances, remove the power supply cord ground prong.

ELECTRICAL REQUIREMENTS

A 115 volt (103.5 min., 126.5 max.), 60 hertz AC only, 15 ampere fused electrical supply is required (time delay fuse or time delay circuit breaker recommended). See Figure 1. *It is recommended that a separate circuit, serving only this appliance, be provided.* Do not use an extension cord.

B ELECTRICAL REQUIREMENTS

for 115 volt models with nameplate amps of 7.6 through 12.0

OBSERVE ALL LOCAL GOVERNING CODES AND ORDINANCES

Do not, under any circumstances, remove the power supply cord ground prong.

ELECTRICAL REQUIREMENTS

A 115 volt (103.5 min., 126.5 max.), 60 hertz AC only, 15 ampere fused electrical supply is required (time delay fuse or time delay circuit breaker required). See Figure 1. It is required that a separate circuit, serving only this appliance, be provided. Do not use an extension cord.

RECEPTACLE WIRING

RECEPTACLE WIRING should be at least as large as 14 gauge. Use copper wire only. It is the personal responsibility and obligation of the customer to provide proper and adequate receptacle wiring installed by a qualified electrician. OBSERVE NATIONAL ELECTRICAL CODE AND ALL LOCAL GOVERNING CODES AND ORDINANCES.

Electrical Connection

Electrical Ground Is Required on This Appliance Recommended Grounding Method

For your personal safety, this appliance must be grounded. This appliance is equipped with a power supply cord having a 3-prong grounding plug. To minimize possible shock hazard, the cord must be plugged into a mating 3-prong grounding type wall receptacle, grounded in accordance with the National Electrical Code and local codes and ordinances. If a mating wall receptacle is not available, it is the personal responsibility and obligation of the customer to have a properly grounded 3-prong wall receptacle installed by a qualified electrician. See Figure 1.

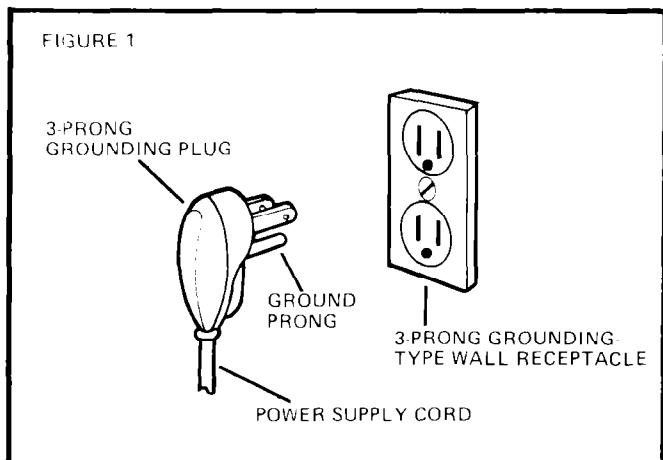

Alternate Grounding Method

If changing and properly grounding the wall receptacle is impossible and where local codes permit (consult your electrical inspector), a temporary adapter may be plugged into the existing 2-prong wall receptacle to mate with the 3-prong power supply cord. See Figure 2. THIS, HOWEVER, IS NOT RECOMMENDED.

If this is done, you must connect the grounding eyelet on the adapter to the wall receptacle cover plate screw and from this same screw, you must connect a separate copper ground wire (#14 minimum) to a grounded cold water pipe.* See Figure 2. Do not ground to a gas supply pipe. Do not connect to electrical supply until appliance is permanently grounded.

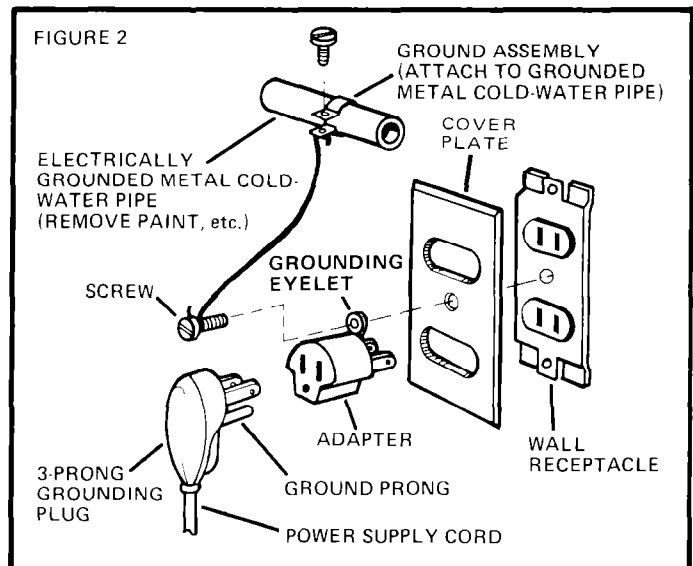

*Cold water pipe must have metal continuity to electrical ground and not be interrupted by plastic, rubber or other electrically insulating connectors (including water meter or pump) without adding a jumper wire at these connections.

C ELECTRICAL REQUIREMENTS

for 230 volt, and 230/208 volt models with nameplate amps up through 12.0

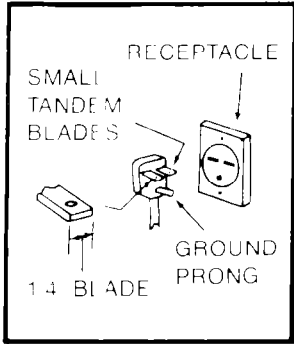

Refer to the chart below for specific wiring and receptacle information to be used.

OBSERVE ALL LOCAL GOVERNING CODES AND ORDINANCES.

Do not, under any circumstances, remove the power supply cord ground prong.

PLUG AND RECEPTACLE DATA	RECEPTACLE VOLTAGE (60 HERTZ AC IN ALL INSTANCES)	NAMEPLATE AMPERES
	MODEL WITH NAMEPLATE OF 230 VOLTS (207 MIN. 253 MAX)	up through 12.0
	MODEL WITH NAMEPLATE OF 230/208 VOLTS (197.6 MIN 253 MAX)	

USE TIME-DELAY FUSE OR TIME DELAY CIRCUIT BREAKER RATING IN AMPS	MINIMUM RECEPTACLE WIRE SIZE SEE BELOW	TYPE OF BRANCH CIRCUIT
 15	14 GAUGE COPPER WIRE ONLY	SINGLE OUTLET ONLY

RECEPTACLE WIRING

RECEPTACLE WIRING should be at least as large as size shown on electrical chart above. Use copper wire only. It is the personal responsibility and obligation of the customer to provide proper and adequate receptacle wiring installed by a qualified electrician. OBSERVE NATIONAL ELECTRICAL CODE AND ALL LOCAL GOVERNING CODES AND ORDINANCES.

Electrical Ground is Required on this Appliance.

A three-wire, single-phase 60 hertz AC only electrical supply is required.

A separate electrical supply is required on a separately fused circuit. Do not fuse ground-neutral.

See chart above for receptacle voltage requirements, proper fuse size, wire size and wiring connections which must conform with rating of the appliance. Do not use an extension cord.

Recommended Grounding Method

For your personal safety, this appliance must be grounded. This appliance is equipped with a power supply cord having a 3-prong grounding plug. To minimize possible shock hazard, the cord must be plugged into a mating 3-prong grounding type wall receptacle, grounded in accordance with the National Electrical Code and local codes and ordinances. If a mating wall receptacle is not available, it is the personal responsibility and obligation of the customer to have a properly grounded 3-prong wall receptacle installed by a qualified electrician.

Installation Instructions For Your Air Conditioner

The installation instructions you use for your air conditioner depend on the model you have. Unpack the accessory parts before attempting to install the unit.

If you have these parts: Follow installation instructions:

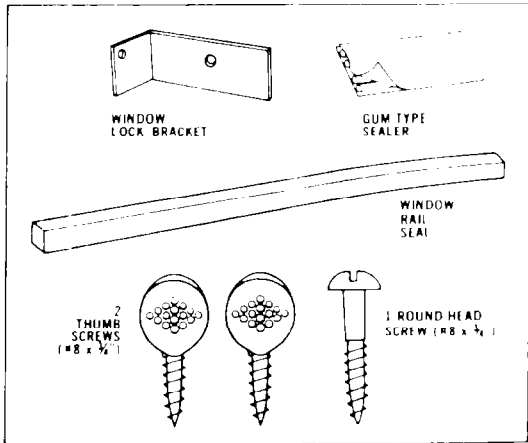

TYPE 1

If you have these parts: Follow installation instructions:

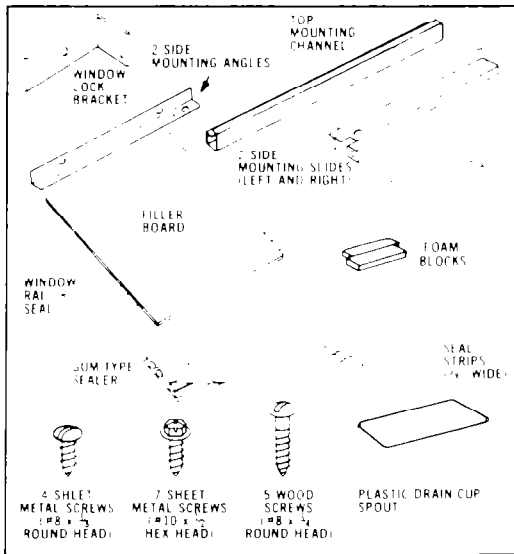

TYPE 2

See page. 11

TYPE 1 Installation Instructions

- To help avoid any installation problems and to help assure trouble-free performance of your new air conditioner, read these installation instructions, as well as your operating instructions, electrical requirements and all other product literature *before* installing your unit.
- Because this air conditioner weighs from approximately 75 to 125 pounds, it is recommended that you have somebody help you install your new unit and that you both use proper lifting techniques to avoid personal injury.
- Inspect the condition of the window where the air conditioner will be installed. Be sure it will support the weight of the unit.

CAUTION:

- Be sure air conditioner does not fall out of window during installation.
- Handle the air conditioner with care. Watch out for the sharp metal fins on the front and rear coils.
- Do not use the water condensate for drinking purposes. It may not be sanitary.

THIS APPLIANCE MUST BE INSTALLED ACCORDING TO ALL APPLICABLE CODES AND ORDINANCES

- 1. Unpack accessory parts** (window lock bracket, gum type sealer, 2 thumb screws, 1 round head screw) before installing your air conditioner. A normal installation can be made with a screwdriver, drill, small level, pocket knife and tape measure.
- 2. Pick the right window.** First, decide what room(s) you want to cool. Then choose a window that will allow the air-conditioned air to flow freely and directly into the room(s) you want cooled. Remember, it's difficult to move air around corners. Choose a window that's also near an electrical outlet. (Refer to ELECTRICAL REQUIREMENTS for receptacle and wiring needed.) Do not use an extension cord.

The window in which you place your air conditioner should have an opening of at least 25 inches in width and at least 16 inches in height. Standard installation parts are supplied for double-hung sash windows up to 38 inches in width.

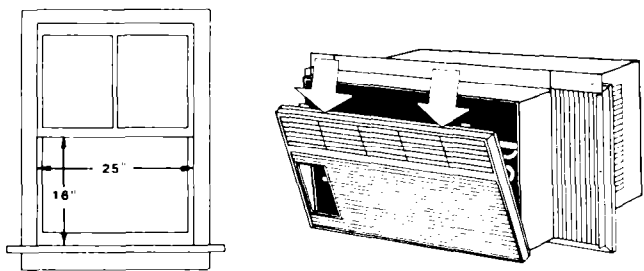

DO NOT BLOCK AIR ENTRY INTO THE SIDE LOUVERS OF THE CABINET.

tilt to the outside for proper water drainage. If necessary, reposition or shim cabinet to provide the proper tilt or side-to-side leveling.

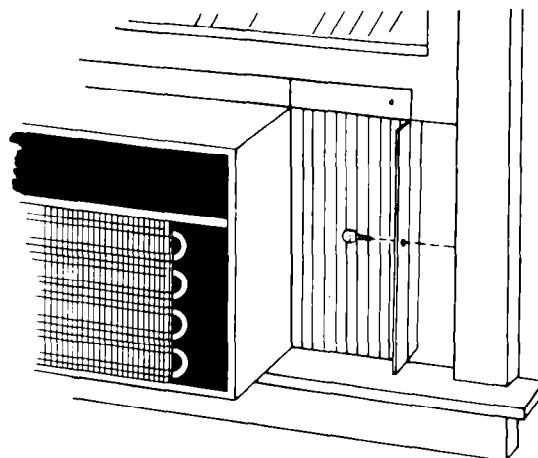

3. Remove front frame by pushing top down and pulling toward you. This protects the frame from damage and makes the air conditioner easier to handle during installation.

4. Center air conditioner in window. Rear of unit must be raised slightly to position lower rail of air conditioner behind and up against back side of window sill. (CAUTION: BE SURE UNIT DOES NOT FALL OUT OF WINDOW.) Lower the window sash firmly behind the top mounting channel.

6. Pull out sliding curtains while holding air conditioner in window. Extend curtains on both sides until they engage window channels. Pulling slightly inward allows curtains to slide easily. Mark and make $\frac{3}{32}$ " pilot holes before installing thumb screws in side handles of curtains. Or, if space is a problem, use holes in top flanges of curtains. (CAUTION: BE SURE UNIT DOES NOT FALL OUT OF WINDOW.)

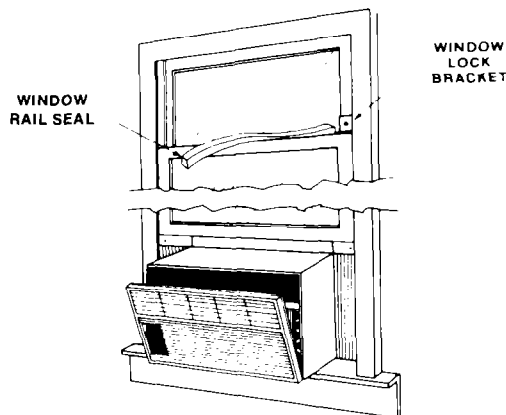
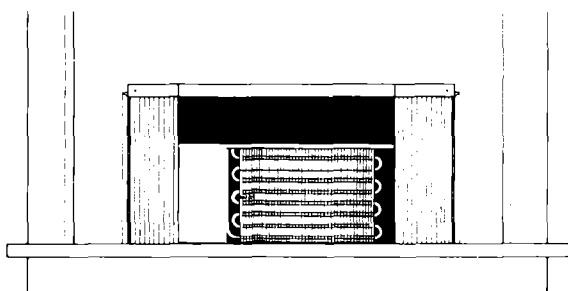

5. Leveling air conditioner is not required in a normal installation. The proper slope is designed into the product. However, be sure you have approximately a one-half bubble ($\frac{1}{4}$ " downward

7. Install window seal and window lock bracket. Press foam window seal into place and cut to proper length. Install lock bracket using round-head screw. Make a $\frac{3}{32}$ " pilot hole first. (CAUTION: KEEP WINDOW LOCK BRACKET INSTALLED AT ALL TIMES TO BE SURE UNIT DOES NOT FALL OUT OF WINDOW. REMOVE ONLY WHEN YOU WISH TO REMOVE AIR CONDITIONER FROM WINDOW.) Seal small openings around installation with gum-type sealer.

8. Attach front by placing bottom edge on clips and pushing top down, then in and up.

TYPE 2 Installation Instructions

THIS APPLIANCE MUST BE INSTALLED ACCORDING TO ALL APPLICABLE CODES AND ORDINANCES

- To help avoid any installation problems and to help assure trouble-free performance of your new air conditioner, read these installation instructions, as well as your operating instructions and electrical requirements *before* installing your unit
- Because this air conditioner weighs from approximately 125 to 200 pounds, it is recommended that you have somebody help you install your new unit and that you both use proper lifting techniques to avoid personal injury.
- Inspect the condition of the window where the air conditioner will be installed. Be sure it will support the weight of the unit.

CAUTION:

- Be sure air conditioner does not fall out of window during installation.
- Handle the air conditioner with care. Watch out for the sharp metal fins on the front and rear coils.
- Do not use the water condensate for drinking purposes. It may not be sanitary.

1. Unpack accessory parts (illustrated below) before installing your air conditioner. A normal installation can be made with a screwdriver, saw, small level, pocket knife, tape measure and drill with $\frac{3}{32}$ " drill bit.

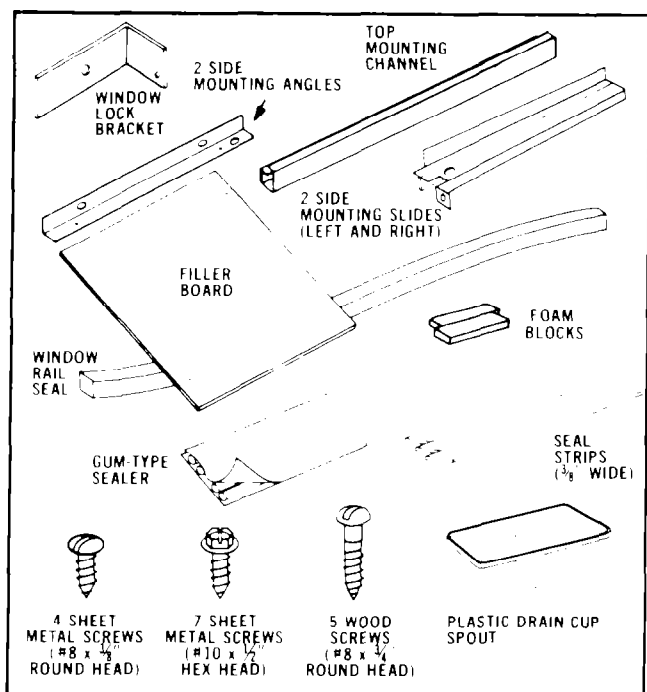

2. Pick the right window. First, decide what room(s) you want to cool. Then choose a window that will allow the air-conditioned air to flow freely and directly into the room(s) you want cooled. Remember, it's difficult to move air around corners. Choose a window that's also near an electrical outlet. (Refer to ELECTRICAL REQUIREMENTS for receptacle and wiring needed.) Do not use an extension cord. The window in which you place your air conditioner should have an opening of at least 26 inches in width and at least 18 inches in height. Standard installation parts are supplied for double-hung windows up to 40 inches in width. For a wide installation up to 54 inches, a special wide-window kit is available as a parts item.

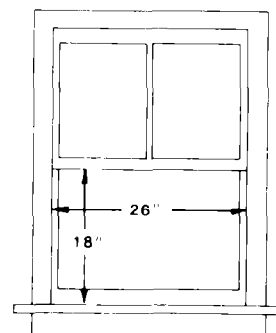

3. Remove front frame by pushing top down and pulling toward you. This protects the frame from damage and makes the air conditioner easier to handle during installation.

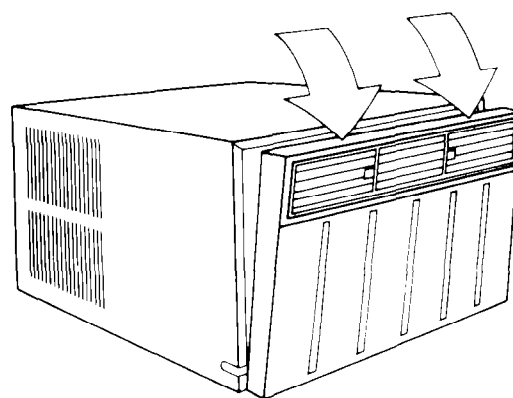

DO NOT BLOCK AIR ENTRY INTO THE SIDE LOUVERS OF THE CABINET.

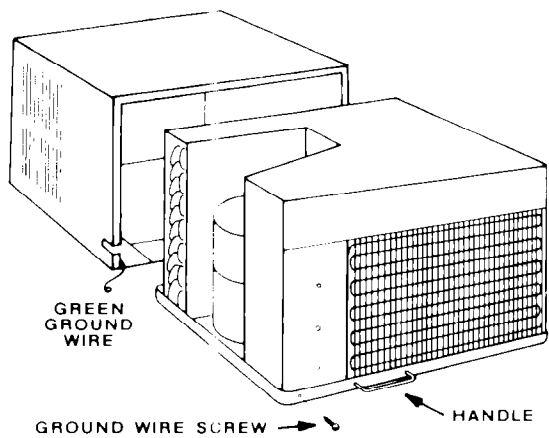

4. Slide unit out of cabinet. First, disconnect the green ground wire at the left-front corner of base of unit by removing retaining screw (save screw for reuse later). Now slide unit out of cabinet by pulling out on handle at bottom.

5. Attach seal strips to cabinet. Place self-adhering strip on window side of bottom flange. Now, starting at the lower corner of the cabinet, apply seal strips over the center line of the pre-drilled holes for one of the side mounting angles, over the center line of pre-drilled holes for the top mounting channel, and over the center line of pre-drilled holes for the other side mounting angle.

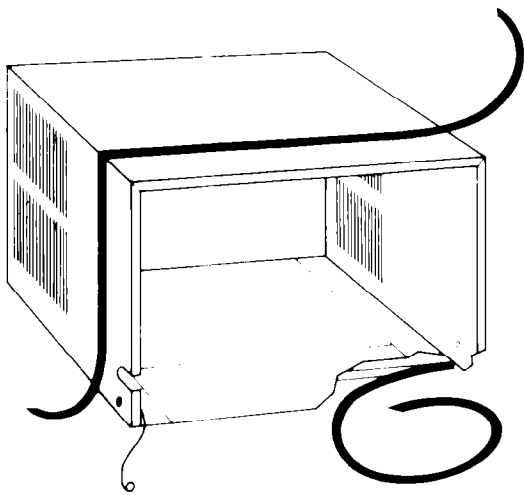

6. Attach side mounting angles to the sides of the cabinet by using four hex-head sheet metal screws. Insert bottom screws first. Be sure flange of each side mounting angle faces inside. Now attach top mounting angle to cabinet by using three hex-head sheet metal screws. Again, be sure tallest flange is facing inside.

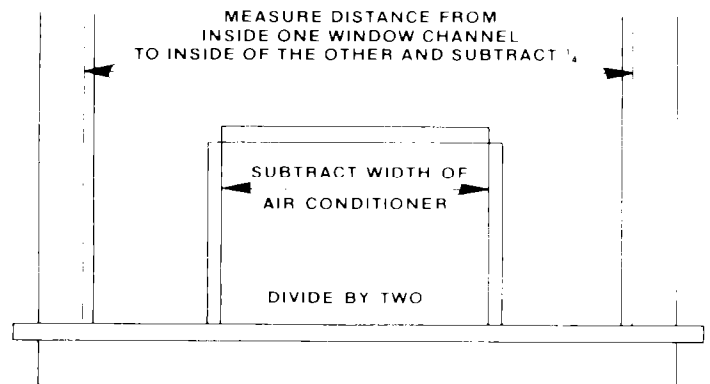
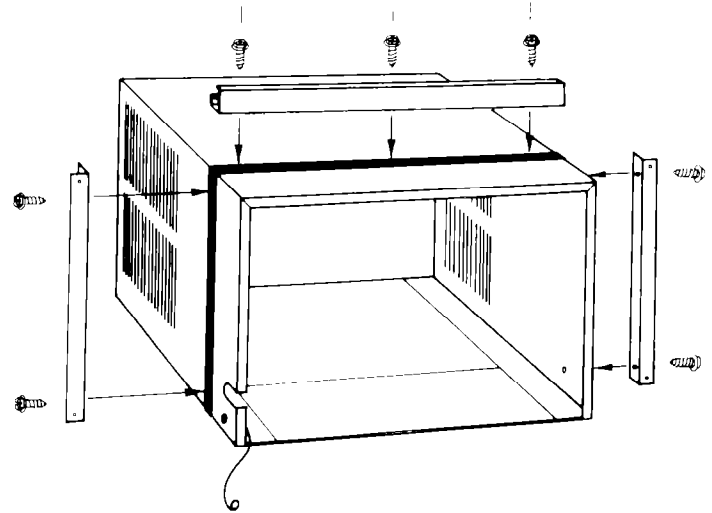

7. Measure and cut filler board to proper sizes. First, measure the distance from inside one window channel to the inside of the other channel and subtract $\frac{1}{4}$ ". Now subtract the width of the air conditioner and divide by 2. This will give you the width to cut each filler board. Be sure to cut the filler board down the mid-section of its longest measurement. Because the filler boards will be equal in width, they will automatically center your air conditioner in your window.

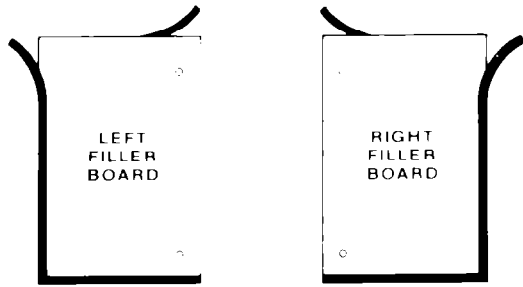

Be sure to use the foam blocks that are provided. See Figure above. (CAUTION: BE SURE CABINET DOES NOT FALL OUT OF WINDOW.)

- 8. Apply seal strips and attach filler boards.** Determine which will be your left and right filler boards. The holes on each board should align with the holes in the side mounting angles. Each filler board should also extend about $\frac{1}{2}$ " above the top edge of the air conditioner cabinet. Now apply the $\frac{3}{8}$ "-wide seal strips on the roomside of each filler board as shown (i.e. along the bottom edge and window channel edge). Also place a seal strip along the top outside edge of each filler board. Now attach the filler boards to the side mounting angles with four, $\frac{3}{8}$ ", round-headed sheet metal screws. Tighten the screws only loosely, so the filler boards can be moved back and forth.

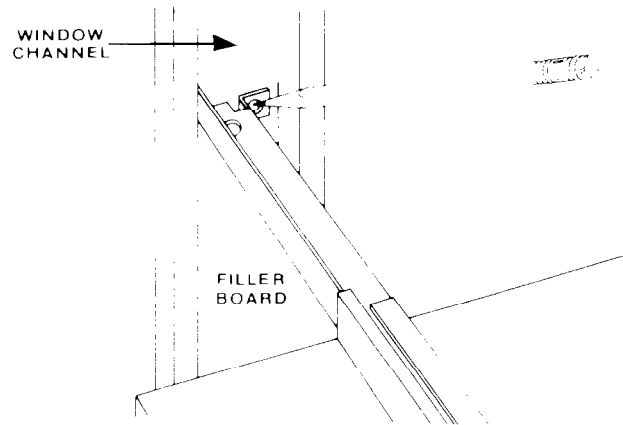

- 9. Insert side mounting slides** all the way into top mounting channel.

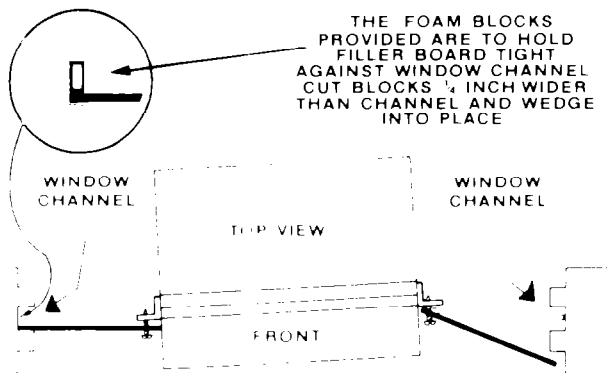
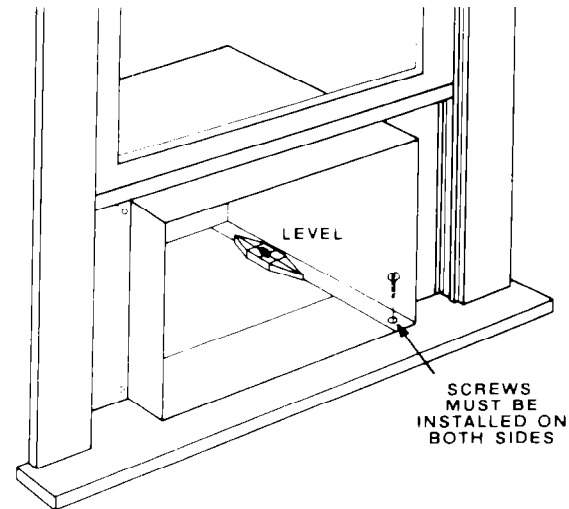

- 10 Place cabinet in window** by turning cabinet to one side to get one filler board into window channel. Now maneuver other filler board into other window channel. Reaching through window opening, push filler boards from outside as far toward you as they will go. Extend the mounting slides outward into the window channels on both sides. Pull the cabinet toward you to position the side mounting slides as far forward in the window channels as possible. Now mark and make a $\frac{3}{32}$ " pilot hole for each wood screw used to secure the slides in the window channels.

- 11 Lower window and level air conditioner.** Lower the window firmly behind the top mounting channel. Leveling the cabinet is not required in a normal installation since the proper slope is designed into the product. However, be sure you have approximately a one-half bubble ($\frac{5}{8}$ " downward tilt to the outside for proper water drainage. If necessary, reposition or shim cabinet to provide the proper tilt or side-to-side leveling. Now tighten all four filler-board screws. Finally, make two $\frac{3}{32}$ " pilot holes into the window sill, using the holes in the cabinet as a guide. Use two wood screws to secure the bottom of the cabinet to the window sill.

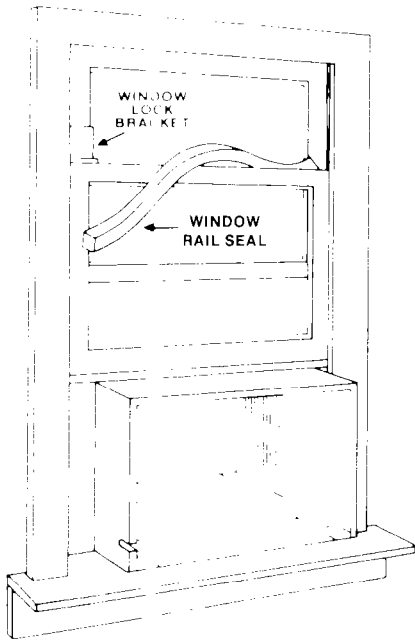

12 Install window seal and window lock bracket.

Press foam window seal into place and cut to proper length. Install lock bracket using wood screws. Make a $\frac{3}{32}$ " pilot hole first. (CAUTION: WINDOW LOCK BRACKET *MUST* BE INSTALLED AT ALL TIMES TO BE SURE AIR CONDITIONER DOES NOT FALL OUT OF WINDOW. REMOVE BRACKET ONLY WHEN YOU WISH TO REMOVE AIR CONDITIONER FROM WINDOW.)

Seal small openings around installation with gum-type sealer.

13 Install plastic drain-cup spout into hole at rear of cabinet. Spout should be facing downward through hole. OPTIONAL: During high humidity, condensate may drip from the outside of your air conditioner onto the ground below. If your air conditioner is installed where this is undesirable, you can direct the water to a more suitable spot by simply attaching a $\frac{5}{8}$ "-inside-diameter, thin-walled hose to the drain spout at rear of cabinet.

14 Insert air conditioner into cabinet. Do not push against sharp fins and plastic parts. Attach green ground wire to the left-front corner of unit base by using retaining screw. (CAUTION: KEEP WIRE CONNECTED WHENEVER AIR CONDITIONER IS IN CABINET. IT IS THERE FOR YOUR ELECTRICAL SAFETY DURING OPERATION AND MAINTENANCE.)

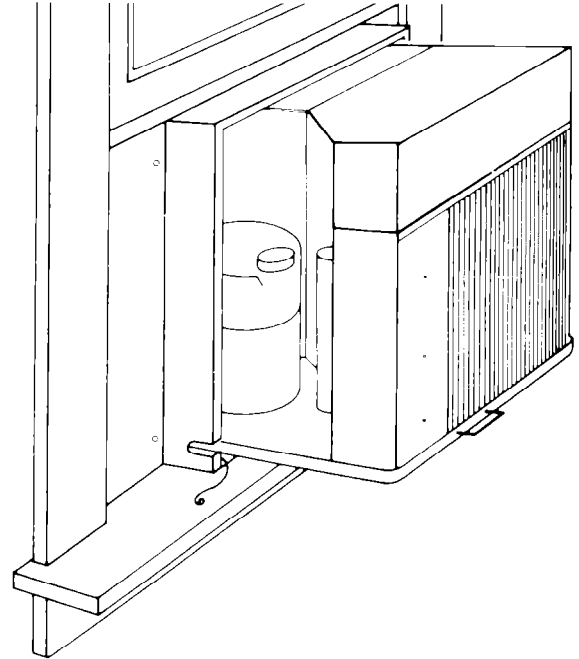

15 Attach front by placing bottom edge on clips and pushing top down, then in and up.

Through-the-wall Installation Instructions

(USE WITH SLIDE-OUT CHASIS MODELS ONLY)

Make sure you have all the necessary tools and supplies needed to complete your installation. Now follow these steps to install your air conditioner through the wall of your house.

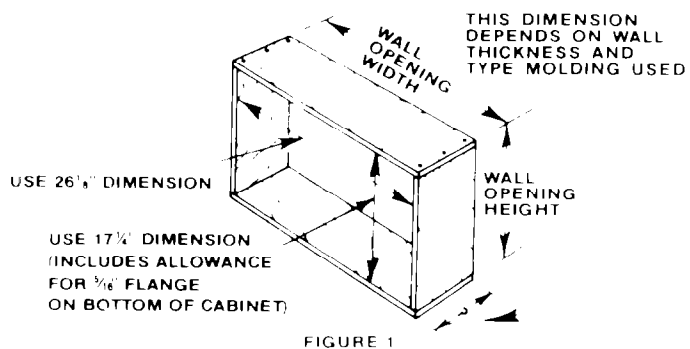

FIGURE 1

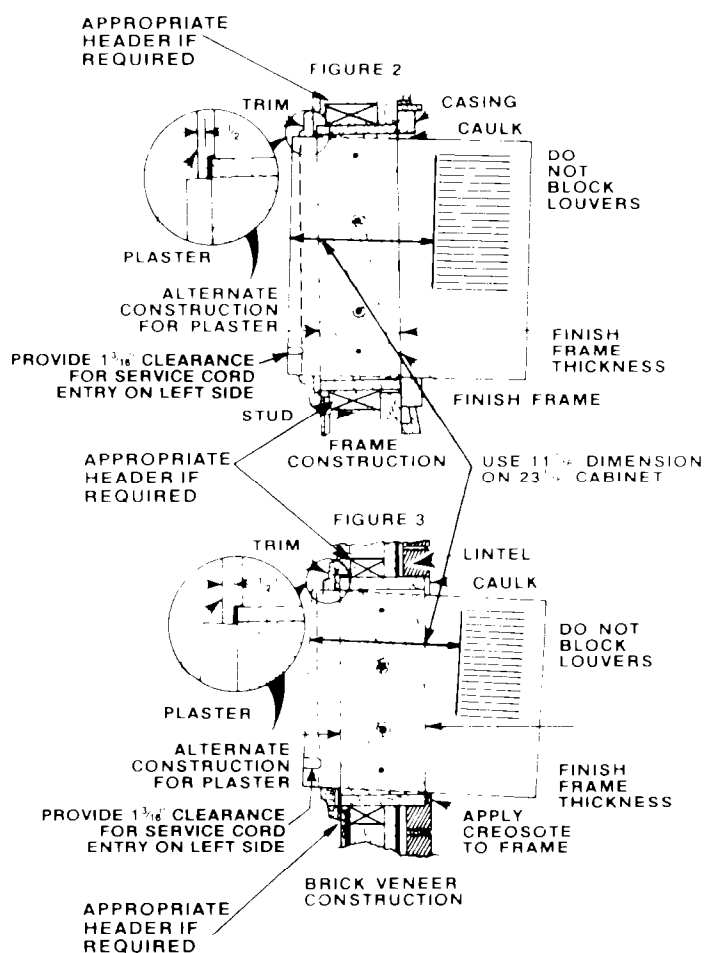

FIGURE 2

FIGURE 3

- A. Select the right location for installing your air conditioner. Choose the type of decorative molding you want to use around the roomside of the cabinet. Your choice affects the finish frame alignment with the inside wall. When using a wood, metal or plastic molding, the finish frame should almost line up with the inside wall. If the wall is plastered to the cabinet and no molding is used, the finish frame must be set into the wall by $\frac{1}{2}$ " (see Figure 2 for frame construction or Figure 3 for brick veneer construction). Cut through two studs for support.
- B. Provide an opening through the wall for a finish frame. Observe all local governing codes and ordinances. For wall opening dimensions, use those shown in Figure 1 and add wood frame thickness (use 1" lumber or heavier). When determining finish frame thickness, be sure you do not cover side cabinet louvers. A 4" minimum clearance between louvers on cabinet sides and adjoining wall allows for proper air-flow into air conditioner.
- C. Construct the finish frame. Apply creosote or something equal to the outside exposed surface.
- D. Install the finish frame in the wall opening. Square and level frame and nail it securely to the studs.
- E. Pull air conditioner unit out of exterior cabinet (read steps 3 and 4 pg. 11 of window installation instruction). TYPE 2
- F. Insert exterior cabinet through the wall opening. Leave overhang into the room at the top of cabinet (after allowing for trim) for service cord entry clearance on left side of cabinet. For proper outside water drainage, shim or reposition cabinet to provide the proper downward tilt to the outside ($\frac{1}{2}$ bubble or $\frac{5}{8}$ ") and side-to-side leveling.
- G. Fill all the spaces between the cabinet and the finish frame with insulation.
- H. Drill holes in the cabinet and attach it securely to finish frame. Use ten #10 x 1" wood screws (four screws for each side and two screws for the top; not included).
- I. Install plastic drain-cup spout (read step 13 of window installation instructions).
- J. Insert air conditioner into cabinet and attach front (read steps 14 and 15 of window installation instructions).
- K. Caulk all outside wall openings around cabinet.
- L. If needed, install decorative molding around roomside of cabinet.

If you need service or help, we suggest you follow these three steps:

1. Before you call for service

If your air conditioner does not seem to be operating properly, check the following before calling for service.

Unit won't run:

1. Is unit plugged in?
2. Is switch ON?
3. Is thermostat set too WARM?
4. Is time-delay fuse blown?
5. Has local power failed?
6. See Energy Savings models below.

Unit blows fuses:

1. Are time-delay fuses used?
2. Is an extension cord being used? (Do not use.)
3. Are you waiting two minutes after turning cooling circuit off before trying to restart unit?

Unit turns on and off, or does not cool room:

1. Is filter clean?
2. Are coils clean? Both evaporator (inside) and condenser (outside)?
3. Is there excessive moisture or heat? (Open vessel cooking, showers, etc.)
4. Set fan to higher speed.
5. See energy saving models below.
6. Set thermostat to a cooler setting

Operating sounds:

1. When your room air conditioner is **operating normally**, you will hear sounds such as:
 - Droplets of water hitting the condenser, causing a "pinging" or "clicking" sound. Water droplets help to cool the condenser.
 - Air movement from the fan, especially on high fan speed setting.
 - Clicks from thermostat cycle.
2. Sounds also may be caused by house construction — such as vibration of the unit due to wall construction or unsteady window mounting area.

Energy saving models

1. Energy saving settings turn fan off when cooling unit stops and cooling unit stays off longer. Use these settings for a little cooling or for some cooling and air drying when cool outside.
2. Set control to "Continuous" fan for normal cooling.

2. If you need service†:

If your Whirlpool appliance ever needs service anywhere in the United States, help is just a phone call away . . . to your nearest Whirlpool franchised TECH-CARE® service representative.

Whirlpool maintains a nationwide network of franchised TECH-CARE service companies to fulfill your warranty and provide after-warranty service and maintenance to keep your WHIRLPOOL appliance in peak condition.

You'll find your nearest TECH-CARE service company listed in your local telephone book Yellow Pages under Washers/Dryers — Repairing or Servicing. Should you not find a listing, dial free the Whirlpool COOL-LINE™ service assistance telephone number (800) 253-1301. When calling from:

Michigan Dial (800) 632-2243
Alaska & Hawaii Dial (800) 253-1121

If you move

To make sure that your appliance is correctly installed and to insure its continued satisfactory operation, please telephone your nearest TECH-CARE® service company for installation or to get the name of a qualified installer. (Installation cost will, of course, be paid by you.)

Helpful hints . . .

You can help your TECH-CARE service representative give you faster service if you include the model and serial number of your appliance when requesting service. Also, retain your sales slip and warranty to verify your warranty status.

Remember . . .

Your TECH-CARE service representative is specially trained in the expert repairing and servicing of your WHIRLPOOL appliances. He can help you maintain the quality originally built into your WHIRLPOOL appliance. So why not take the time, now, to look up his telephone number and jot it down in the space provided below.

My TECH-CARE service representative's telephone number is:

My appliance model number is:

Its serial number is:

Purchase and/or installation date:

If you need to call your TECH-CARE service representative, tell him the model and serial number of your appliance.

You will find these numbers on the model and serial number plate attached to the front of the air conditioner. You can see it after removing the plastic front panel.



SYMBOL
OF QUALITY
SERVICE

3. If you have a problem‡:

Call Whirlpool Corporation in Benton Harbor at the COOL-LINE service assistance telephone number (see Step 2) or write:

Mr. Stephen E. Upton, Vice President
Whirlpool Corporation
Administrative Center
2000 U.S. 33 North
Benton Harbor, Michigan 49022

‡If you must call or write, please provide: your name, address, telephone number, type of appliance, brand, model, serial number, date of purchase, the dealer's name and complete description of the problem. This information is needed in order to better respond to your request for assistance.



Benton Harbor, Michigan. Automatic Washers, Clothes Dryers, Freezers, Refrigerator-Freezers, Ice Makers, Dishwashers, Built-in Ovens and Surface Units, Ranges, Microwave Ovens, Compactors, Room Air Conditioners, Dehumidifiers, Central Heating and Air Conditioning Systems.



FSP is a registered trademark of Whirlpool Corporation for quality parts. Look for this symbol of quality whenever you need a replacement part for your Whirlpool appliance.

FSP® replacement parts will fit right and work right because they are made to the same exacting specifications used to build every new Whirlpool appliance.

Part No. 947596 B